

دفترچه شماره ۱

عصر جمعه

۸۵/۱۲/۱۱

اگر دانشگاه، اصلاح شود: مملکت اصلاح می‌شود.
امام خمینی (ره)

جمهوری اسلامی ایران
وزارت علوم، تحقیقات و فناوری
سازمان سنجش آموزش کشور

آزمون ورودی
دوره‌های کارشناسی ارشد ناپیوسته داخل
سال ۱۳۸۶

مجموعه مهندسی برق
(کد ۱۲۵۱)

شماره داوطلبی:

نام و نام خانوادگی داوطلب:

مدت پاسخگویی: ۴۵ دقیقه

تعداد سؤال: ۲۵

مواد امتحانی رشته مجموعه مهندسی برق، تعداد و شماره سؤالات

ردیف	مواد امتحانی	تعداد سؤال	از شماره	تا شماره
۱	زبان عمومی و تخصصی	۲۵	۱	۲۵

اسفند ماه سال ۱۳۸۵

استفاده از ماشین حساب مجاز نمی‌باشد.

Please read the passages carefully and choose the best answers for each of the questions.

Passage 1:

Central to an autonomous entity are the rules of behavior governing how it must act or react to the information collected by the detector from the environment and its neighbors. These rules determine into what state the entity should change and also what local knowledge should be released via the effector to the environment.

In order to adapt itself to a problem without being explicitly told what to do in advance, an autonomous entity must modify the rules of its behavior over time. This ability, responding to local changing conditions, is known as the individual's learning capability. Worth noting is that randomness plays a part in the decision making process of an autonomous entity despite the presence of a rule set. It allows an autonomous entity to explore uncharted territory despite evidence that it should exploit only a certain path. On the other hand, randomness helps the entity resolve conflict in the presence of equal support for suggestions to act in different ways in its own best interests and avoid being stuck by randomly choosing an action in local optima.

The environment acts as the domain in which autonomous entities are free to roam. This is a static view of the environment. The environment of a NIC (nature-inspired computing) system can also act as the "noticeboard" where the autonomous entities post and read local information. In this dynamic view, the environment is constantly changing.

1_ If the individual's learning capacity is not high enough, an autonomous entity

- | | |
|--|--|
| 1) cannot adapt itself to a problem. | 2) can respond to local changes. |
| 3) modifies the rules of its behavior. | 4) should be told what to do in advance. |

2_ Randomness being a part of decision making process

- 1) leads to confusion because of the presence of a rule set.
- 2) cannot work in the presence of a rule set.
- 3) allows the autonomous entity to explore unknown areas but helps it resolve possible conflicts.
- 4) helps the autonomous entity to follow a pre-arranged path.

Passage 2:

Forward-looking electromechanical applications require more sophistication and flexibility from both the hardware and software points of view. Many features which were considered luxury items in a product just a few years ago have now become standard items. This reality has led to new requirements for system design. The integration of design and control becomes even more relevant in the systems approach. These are important aspects not only for industrial research and development personnel but also for academicians. The specific application often dictates the system design requirements and control system characteristics. The applications considered emphasize the demand for high-performance systems which has introduced an increasingly challenging system design problem. These systems involve multi-energy domains, exhibit significant dynamic changes, and operate in environments where unpredictable disturbances are possible.

The applications discussed in this paper include robot manipulators, high-speed and high-precision magnetic bearing systems, atomic resolution systems, and their control using digital signal processing boards. In general, the design procedure involves the integration of design and control. Analytical and graphical descriptions for modeling physical dynamic systems

are necessary for such an integration. Graphical descriptions, such as the bond graph representation, can provide techniques for modifying system characteristics leading to proper system designs. These fundamental concepts are applicable to single and multi-energy domain systems. These systems include one or more of the following energy domains: electrical, mechanical, magnetic, chemical, and thermo-fluidic. System design of engineering systems requires a clear understanding of the system dynamic behavior and the performance specifications sought. This in turn implies the need for predicting the system behavior with and without a control system.

3_ Which of the following are needed for proper system design of forward-looking electromechanical applications?

- | | |
|--|--|
| 1) Analytical and graphical descriptions. | 2) Disintegration of design and control. |
| 3) Environments with unpredictable disturbances. | 4) Use of analog signal processing boards. |

4_ Based on the text, what is most relevant in the systems approach?

- | | |
|--|----------------------------------|
| 1) A clear understanding of system dynamics. | 2) Combining design and control. |
| 3) Knowledge of performance specifications. | 4) Predicting system behavior. |

Passage 3:

MEMS (Micro-Electro-Mechanical Systems) and Nano devices are extremely small - for example, MEMS and Nanotechnology has made possible electrically-driven motors smaller than the diameter of a human hair - but MEMS and Nanotechnology is not primarily about size. It is also not about making things out of silicon, even though silicon possesses excellent materials properties, which make it an attractive choice for many high-performance mechanical applications; for example, the strength-to-weight ratio for silicon is higher than many other engineering materials which allows very high-bandwidth mechanical devices to be realized. Instead, the deep insight of MEMS and Nano is as a new manufacturing technology, a way of making electromechanical systems using batch fabrication techniques similar to those used for integrated circuits, and uniting these electromechanical elements with electronics.

MEMS and Nanotechnology are extremely diverse technologies that can significantly affect every category of commercial and military product. They are already used for tasks ranging from in-dwelling blood pressure monitoring to active suspension systems for automobiles. Their nature and diversity of useful applications make it potentially a far more pervasive technology than even integrated circuit microchips. Historically, sensors and actuators are the most costly and unreliable part of a macroscale sensor-actuator-electronics system. However, MEMS and Nanotechnology allows these complex electromechanical systems to be manufactured using batch fabrication techniques increasing the reliability of the sensors and actuators to equal those of integrated circuits at a much lower cost.

MEMS are the integration of mechanical elements, sensors, actuators, and electronics on a common silicon substrate through microfabrication technology. While the electronics are fabricated using integrated circuit (IC) process sequences, the micromechanical components are fabricated using compatible "micromachining" processes that selectively etch away parts of the silicon wafer or add new structural layers to form mechanical and electromechanical devices. MEMS can revolutionize nearly every product category by bringing together silicon-based microelectronics with micromachining technology, making

nearly every product category by bringing together silicon-based microelectronics with micromachining technology, making possible the realization of complete systems-on-a-chip. It is an enabling technology allowing the development of smart products, augmenting computational ability of microelectronics with the perception and control capabilities of microsensors and microactuators and expanding the space of possible designs and applications.

5- What are the strong points of MEMS and Nanotechnology?

- | | |
|--|---|
| 1) Low cost and computational ability. | 2) High ability and excellent materials properties. |
| 3) Small size and computational ability. | 4) Small size, computational ability, and lowcost. |

6- Where are MEMS manufactured on?

- | | |
|---|---|
| 1) On a chip. | 2) On a silicon wafer. |
| 3) On suspension systems for automobiles. | 4) On motors smaller than the diameter of human hair. |

7- How are MEMS manufactured?

- | | |
|------------------------------------|------------------------------------|
| 1) By integrated circuits. | 2) By micromachining technology. |
| 3) By microelectronics technology. | 4) By microfabrication technology. |

Passage 4:

Face recognition technology that could revolutionize security systems worldwide has been developed by computer scientists at Sheffield Hallam University. The new specialist software can produce an exact 3D image of a face within 40 milliseconds. Other 3D systems that have been trailed have proved unworkable because of the time it takes to construct a picture and an inaccurate result. The ground-breaking invention, by experts in the University's Materials and Engineering Research Institute (MERI) was tested by Home Secretary Charles Clarke on a recent visit to Sheffield. It could be used for tighter security in airports, banks, and government buildings and ID cards.

The breakthrough comes days after members of parliament (MPs) backed the compromise plans for identity cards, meaning from 2008 people applying for a new passport will also get an identity card, with their biometric details stored on a central register. The new technology works by projecting a pattern of light onto the face, creating a 2D image, from which 3D data is generated. Biometric features are extracted by a "parameterization" process, giving a digital mapping of a face that would form part of a fool-proof security system.

It is said that, this technology could be used wherever there is a need for heightened security. It is well suited to a range of applications including person identification from national databases, access control to public and private locations, matching 3D poses to 2D photographs in criminal cases, and 3D facial biometric data for smart cards such as ID and bank cards. We have developed a viable, working system at the cutting edge of 3D technology.

8- The previous software for 3D face recognition are unworkable because they are:

- | | | | |
|----------|----------|-------------------------|-------------------------|
| 1) Fast. | 2) Slow. | 3) Slow and inaccurate. | 4) Fast but inaccurate. |
|----------|----------|-------------------------|-------------------------|

9- In the new technology discussed in the passage, 3D data is generated from

- 1) ID image. 2) Light patterns. 3) Biometric features. 4) Digital mapping.
-

10- The new technology could be used for:

- 1) Access control. 2) Identification in criminal cases.
3) Person identification. 4) All of the above.
-

Passage 5:

The ionization in the ionosphere is generated when radiation from the sun strikes the gas molecules in the upper atmosphere. The radiation is of sufficient intensity that it gives the electron in some molecules sufficient energy to leave the molecular structure. This leaves a free electron and the gas molecule, having one electron too few becomes a positive ion. At very high altitudes the atmosphere is very thin, and as a result the levels of ionization are very low. As the atmosphere become denser, so the level of ionization starts to rise. However the ionization process uses up the energy of the radiation, and after a certain distance the energy of the radiation is such that it does not ionize as many gas molecules as before and the level of ionization begins to fall. It is also found that for the higher layers including the F and E layers most of the ionization results from ultra violet light. The D layer being at a lower altitude results mainly from X-rays that are able to penetrate further into the atmosphere.

It is also found that the free electrons and positive ions slowly recombine. In other words the radiation is causing them to ionize, and then they slowly recombine afterwards. In chemistry this state of affairs is called a dynamic equilibrium. It means that if the source of radiation is removed, then the levels of ionization will fall. As a result the D layer disappears after nightfall, and the E layer is greatly reduced in intensity. In view of the high levels of ionization in the F layers and the fact that the air density is so much less, it takes longer for the recombination process to take place and consequently it remains over night, although its level is reduced.

1- At very high altitudes of the atmosphere the level of ionization is low because:

- 1) Atmosphere is dense. 2) Atmosphere is not dense.
3) Radiation from the sun is low. 4) Radiation from the sun is high.
-

2- At which layer of atmosphere ionization results from ultra violet light?

- 1) Low layers of the atmosphere.
2) Only the E layer of the atmosphere.
3) High layers of atmosphere including the E and F layers.
4) Medium layers of the atmosphere including the D layer.
-

- 1) Source of radiatoin is removed.
- 2) Longer recombination process takes place.
- 3) Air density is so much high.
- 4) 2 and 3.

Passage 6:

WiMedia the next generation of wireless connectivity, is raising some interesting questions about privacy. WiMedia, which underlies consumer technologies such as Certified Wireless USB and the planned next iteration of Bluetooth, is based on the concept of ultrawideband radio. It uses short-range, very-low-power signals transmitted across a vast expanse of the radio spectrum - from 3.1 to 10.6 GHz. Traditional radio, on the other hand, uses a much higher-power signal across a narrow band of spectrum.

In the United States, the authority to regulate use of the radio spectrum falls to the Federal Communications Commission (FCC). U.S. courts have consistently ruled that the federal government has the power to regulate the airwaves, because radio is interstate commerce. But can the FCC really claim jurisdiction over the minuscule power levels used by WiMedia radios?

The answer to the question is important because the FCC restricts what radio broadcasters, whether licensed (as in the case of radio or TV stations) or unlicensed (as in the case of the millions of people who own Wi-Fi base stations), can do. On many licensed radio services, encryption is not allowed, as a condition of licensing. Amateur radio operators, for example, have never been allowed to send encrypted traffic; they would lose their licenses if they did.

In contrast, concerned that users be able to trust their own wireless systems, the coalition of electronics companies behind WiMedia - the WiMedia Alliance - demands that all ultrawideband radio systems sold under the WiMedia banner be capable of strong hardware encryption and that for some applications, using this encryption capability be mandatory.

So far, FCC regulations that deal with ultrawideband technologies have made no mention one way or the other of the use of encryption. But could the federal government use the authority of the FCC to enforce a law requiring that all ultrawideband transmissions be in the clear? It's not such a preposterous idea: the government's hostility to encryption was demonstrated in the 1990s, when it tried to restrict the use of Internet-based encryption technologies. In the end, the borderless nature of the Internet caused the government to admit defeat. There is no such obstacle to controlling low-power radio, however.

14- What is meant by WiMedia?

- 1) WiMedia is the next generation of wireless connectivity based on the concept of ultrawideband radio.
- 2) WiMedia is the next generation of wireless connectivity that is banned by the FCC.
- 3) WiMedia is the next generation of wireless connectivity that uses high power signal across the radio spectrum.
- 4) WiMedia is the next generation of wireless connectivity contradicted by the FCC.

15_ What is the constraining factor that FCC imposes upon radio broadcasters?

- 1) Encryption is mandatory
- 2) Encryption technologies to be licensed.
- 3) Encryption is not authorized.
- 4) Licenses to be obtained.

16_ In what category does the power of FCC lie?

- 1) Power to regulate use of the radio spectrum.
- 2) Power to provide services for radio broadcasters.
- 3) Power to restrict broadcasters.
- 4) Full jurisdiction over the airwaves to regulate use of the radio spectrum.

17_ By reading the above passage, which of the following statements would best explain what the passage reveals?

- 1) FCC may not have full authority over the users but it is successful in restricting encryption.
- 2) FCC has full authority and is capable of banning encryption.
- 3) FCC's authority is undeniable and can be an obstacle in controlling low-power radio.
- 4) None of the above.

Passage 7:

A few months ago Timothy Broderick, a professor of surgery and biomedical engineering at the University of Cincinnati, chose an unusual place for an experiment in surgical robotics. As part of the NASA Extreme Environment Mission Operations, or NEEMO, project, he headed out to the Aquarius habitat, located 19 meters underwater off Key Largo, Florida, and in a cramped laboratory he set up an experimental two-armed surgical robot.

Broderick requested the help of another surgeon, Mehran Anvari of McMaster University, in Hamilton, Ont., Canada, who controlled the robot from his office 2000 kilometers to the north. Despite a delay of up to 2 seconds, Anvari was able to successfully simulate complex surgical tasks, such as suturing a vein on a latex anatomical model. The surgical robot used by Broderick and Anvari was a modified version of a system originally developed in the early 1990s by Phil Green, a researcher at SRI International, for the U.S. military. The highly influential SRI project encouraged the start-up of two companies to address the civilian robotic surgery market: Computer Motion, in Goleta, Calif., and Intuitive Surgical, in Sunnyvale, California.

In 2001, Jacques Marescaux, a surgeon at the University of Strasbourg, in France, worked with Computer Motion to modify its system and perform the first remote surgery on a human patient, a gallbladder removal procedure called laparoscopic cholecystectomy. Using a dedicated high-speed connection, Marescaux controlled the robot from New York City while the patient lay in an operating room in Strasbourg.

In 2003, a lengthy patent litigation ended with the merger of Computer Motion and Intuitive Surgical. Under the name of Intuitive Surgical, the merged company is now the only one to commercialize a robotic surgical system approved by the US Food and Drug Administration. The FDA-approved procedures include general laparoscopic surgery, chest surgery, certain

18_ Under whose control, with what, and in which state was the experimental surgery mentioned in the above passage performed?

- 1) Jacques Marcescaux, surgical robot, France.
- 2) Mehran Anvari, a two armed robot, Florida.
- 3) Phil Green, surgical robot, Florida.
- 4) Timothy Broderick, a two armed robot, Canada.

19_ Which country was the pioneer in performing the remote surgery?

- 1) France.
- 2) Canada.
- 3) U.S.A.
- 4) None of the above.

20_ Who originally developed the remote surgery system?

- 1) Jacques Marescaux.
- 2) Mehran Anvari.
- 3) Phil Green.
- 4) Timothy Broderick.

21_ Under what circumstances was the experimental remote surgery performed?

- 1) In an inconvenient, uncommon condition.
- 2) In an operating room in Strasbourg.
- 3) In cooperation with Computer Motion and Intuitive Surgical.
- 4) With a high speed connection.

22_ On which human organ was the first remote surgery performed?

- 1) Chest.
- 2) Gallbladder.
- 3) Heart.
- 4) Kidney.

Passage 8:

In today's mobile market, an operator usually charges customers with a simple billing and accounting scheme. A flat rate based on subscribed services, call durations, and transferred data volume is usually enough in many situations. However, with the increase of service varieties in 4G systems, more comprehensive billing and accounting systems are needed. Customers may no longer belong to only one operator, but instead subscribe to many services from a number of service providers at the same time. It may be very inconvenient for a customer to deal with multiple service providers. Instead, a brokering service can be provided. Customers do not have to waste time handling all the financial transactions involved. To achieve this, operators need to design new business architecture, accounting processes, and accounting data maintenance. Moreover, equalization on different charging schemes is also needed. This is because different billing schemes may be used for different types of services (e.g., charging can be based on data, time, or information). It is challenging to formulate one single billing method that covers all the billing schemes involved. Furthermore, 4G networks support multimedia communications, which consists of different media components with possibly different charging units. This adds difficulty to the task of designing a good charging scheme for all customers. Besides, the media components may have different QoS requirements. It is very complicated to decide a good tariff for all the possible components. In order to build a structural billing system for 4G networks, several frameworks have already been studied. The requirements on these frameworks include scalability

In addition to terminal mobility, personal mobility is a concern in mobility management. Personal mobility concentrates on the movement of users instead of users' terminals, and involves the provision of personal communications and personalized operating environments. When there is a video message addressed to the mobile user, no matter where the user is located or what kind of terminal is being used, the message will be sent to the user correctly. A personalized operating environment, on the other hand, is a service that enables adaptable service presentations (in order to fit the capabilities of the terminals in use regardless of network types). Currently, there are several frameworks on personal mobility found in the literature. Mobile-agent-based infrastructure is one widely studied solution. In this infrastructure, each user is usually assigned a unique identifier and served by some personal mobile agents (or specialized computer programs running on some servers). These agents act as intermediaries between the user and the Internet. A user also belongs to a home network that has servers with the updated user profile (including the current location of the user's agents, user's preferences, and currently used device descriptions). When the user moves from his/her home network to a visiting network, his/her agents will migrate to the new network. When somebody makes a call request to a user, say Mary, the caller's agent first locates Mary's agent by making a location request to her home network. By looking up Mary's profile, her home network sends back the location of Mary's agent to the caller's agent. Once the caller's agent identifies Mary's location, the caller's agent can directly communicate with her agent. Different agents may be used for different services. A mobile agent-based infrastructure uses four assistants (user assistant, HTTP assistant, mail assistant, and FTP assistant) to personalize user operating environments. However, there are other personal mobility frameworks that do not rely on mobile agents.

- Which choice is closer to the passage?

- 1) Agents in a mobile agent-based infrastructure belong to one network.
- 2) In video message transmission, the person's location is an important issue.
- 3) In a mobile agent-based infrastructure, agents of users communicate with each other directly all the time.
- 4) In a mobile agent-based infrastructure, communication is done by agents.

- According to the passage, which statement is correct?

- 1) In 4G, all media have the same tariff.
- 2) Creating one billing system for all of communication systems is not easy because there are varying services.
- 3) A simple billing system suffices for 4G.
- 4) An exact billing system is required only for multimedia.

- What activity is most closely related to personal mobility?

- 1) Carrier of persons.
- 2) Location management.
- 3) Mobility management.
- 4) Terminal mobility

۴۰- تابع $f(z) = \operatorname{cosec} \left(\frac{1}{z+1} \right)$ از متغیر مختلط z را در نظر می‌گیریم. در مورد نقاط تکین (Singular) و قطب‌های تابع کدام عبارت درست است؟

- (۱) بینهایت قطب ساده و یک نقطه تکین اساسی دارد.
 (۲) بینهایت قطب مکرر دارد.
 (۳) فقط یک نقطه تکین اساسی دارد و قطب ندارد.
 (۴) $z = 1$ تنها نقطه تکین تابع است.

۴۱- مطلوبست محاسبه $\oint_{|z|=2} \frac{\operatorname{coth} z}{z-i} dz$:

- (۱) $2\pi i(\cot i - 2i)$ (۲) $2\pi i(\cot i + 2i)$ (۳) $2\pi i(\operatorname{coth} i - i)$ (۴) $2\pi i(\operatorname{coth} i + i)$

۴۲- اتومبیل I در جاده ناگهان توقف می‌کند و اتومبیل II از عقب به آن برخورد می‌نماید در حالی که ناظران A، B و C شاهد آنها هستند. اگر احتمال

اینکه این ناظران به درستی رویداد را ملاحظه و گواهی کرده باشند به ترتیب برابر $0/9$ ، $0/8$ و $0/7$ باشد، آنگاه احتمال اینکه لااقل دو شاهد رویداد را صحیح گواهی نمایند برابر کدام است؟

- (۱) $0/892$ (۲) $0/902$ (۳) $0/908$ (۴) $0/994$

۴۳- X یک متغیر تصادفی با میانگین $\frac{5}{4}$ و دارای تابع چگالی احتمال زیر است:

$$f_X(x) = \begin{cases} x^2 & 0 \leq x \leq 1 \\ b & 1 < x < a \\ 0 & \text{سایر جاها} \end{cases}$$

مقادیر a و b به ترتیب برابر است با:

- (۱) $b = \frac{1}{4}, a = 2$ (۲) $b = \frac{1}{4}, a = 2$ (۳) $b = \frac{1}{4}, a = 2$ (۴) $b = \frac{2}{3}, a = 2$

۴۴- اگر X و Y دو متغیر تصادفی نمایی مستقل با میانگین‌های به ترتیب $\frac{1}{\mu_1}$ و $\frac{1}{\mu_2}$ باشند، آنگاه توزیع متغیر تصادفی $Z = \min(X, Y)$ و میانگین آن

به ترتیب عبارت خواهد بود از:

- (۱) نمایی و $\frac{1}{\mu_1} + \frac{1}{\mu_2}$ (۲) نمایی و $\frac{1}{\mu_1 + \mu_2}$ (۳) ارلانگ مرتبه ۲ و $\frac{1}{\mu_1} + \frac{1}{\mu_2}$ (۴) ارلانگ مرتبه ۲ و $\frac{1}{\mu_1 + \mu_2}$

۴۵- تابع احتمال متغیر تصادفی X و متغیر تصادفی $(Y|X)$ به صورت زیر داده شده است:

$$f_{Y|X}(y|x) = \begin{cases} \frac{2y^2}{x^2} & 0 < y < x \\ 0 & \text{سایر جاها} \end{cases} \quad \text{و} \quad f_X(x) = \begin{cases} 2x^2 & 0 < x < 1 \\ 0 & \text{سایر جاها} \end{cases}$$

در این صورت $E(X|Y)$ کدام است؟

- (۱) $\frac{1-y}{\ln(y)}$ (۲) $\frac{\ln(y)}{1-y}$ (۳) $\frac{y-1}{\ln(y)}$ (۴) $E(X|Y)$ وجود ندارد.

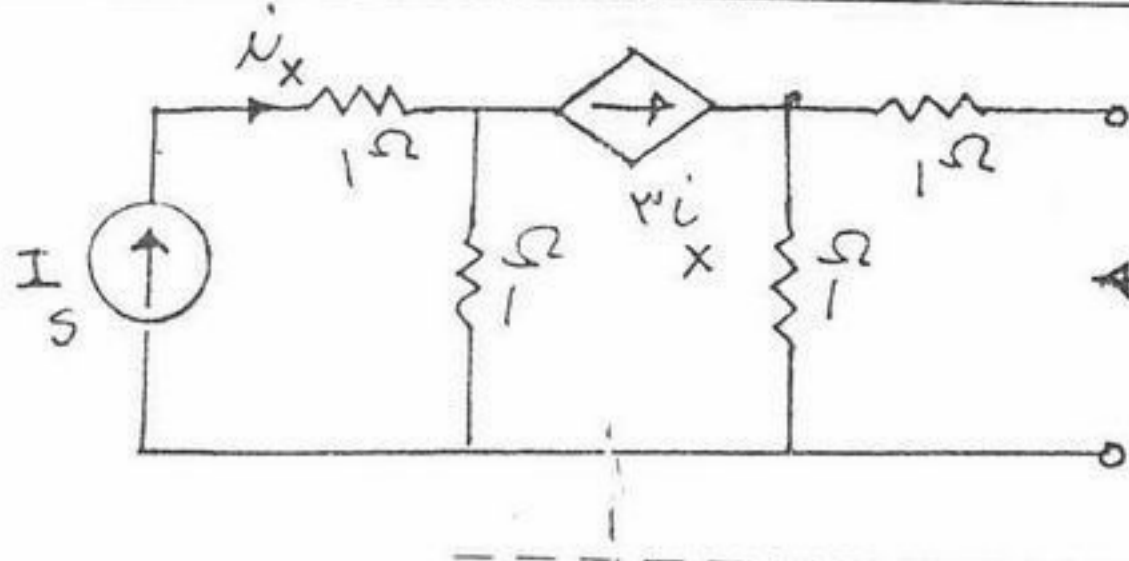

۴۶ - مقاومت معادل تونن مدار شکل مقابل کدام است؟

- (۱) 1Ω
- (۲) $1\frac{1}{3}\Omega$
- (۳) $1/5\Omega$
- (۴) 2Ω

۴۷ - در مدار زیر (با فرض جواب بکنا)، N_1 و N_2 از مقاومت‌های خطی تشکیل شده‌اند و $i = \frac{1}{V}(v_s + i_s)$ می‌باشد. به جای مقاومت 4Ω چه مقاومتی را بگذاریم تا مقاومت کل مدار از دو سر a و b برابر $\frac{1}{4}\Omega$ شود؟

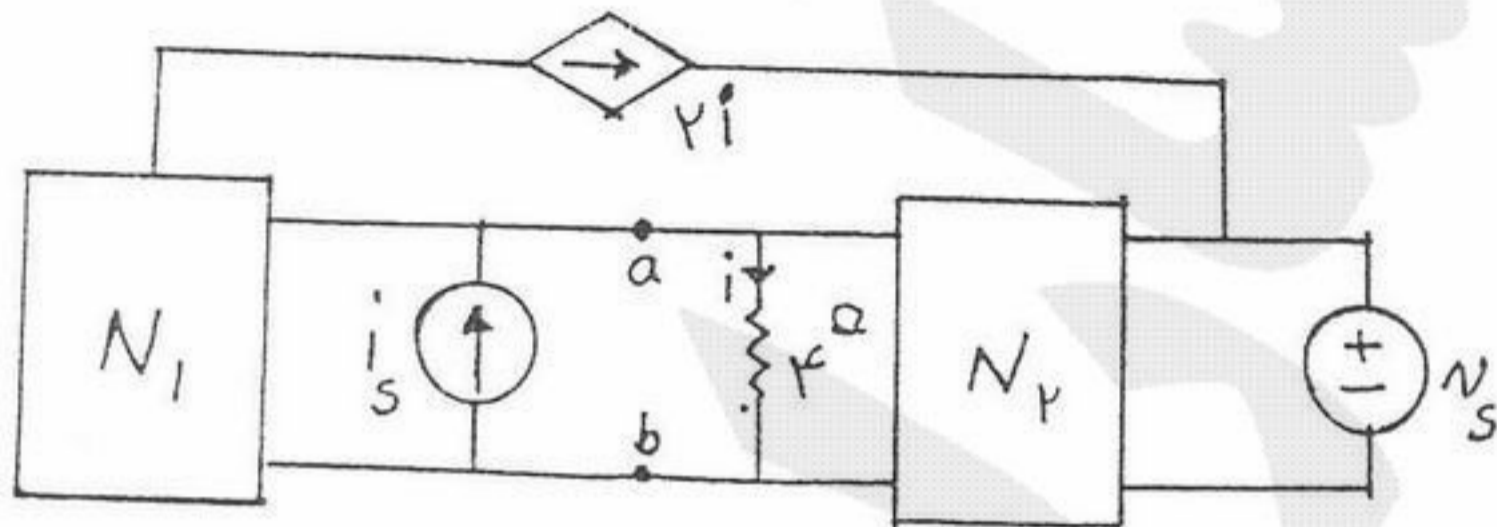

- (۱) $\frac{1}{4}\Omega$
- (۲) $\frac{1}{5}\Omega$
- (۳) 2Ω
- (۴) 4Ω

۴۸ - در مدار شکل زیر فرکانس تشدید کدام است؟

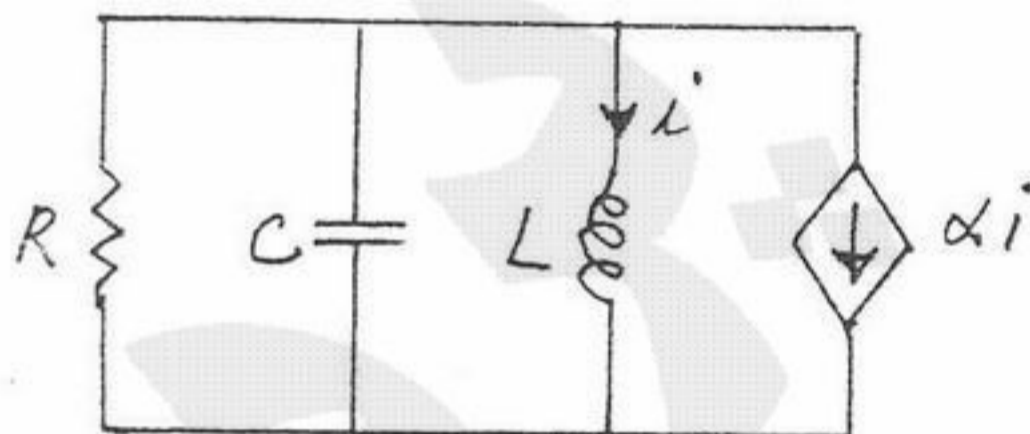

- (۱) $\sqrt{\frac{\alpha-1}{LC}}$
- (۲) $\sqrt{\frac{\alpha}{LC}}$
- (۳) $\sqrt{\frac{1-\alpha}{LC}}$
- (۴) $\sqrt{\frac{1+\alpha}{LC}}$

۴۹ - در مدار شکل مقابل V_s یک منبع ولتاژ dc است. در چه زمانی ولتاژ دو سر خازن دو برابر V_s می‌شود؟ (ولتاژ اولیه خازن صفر است)

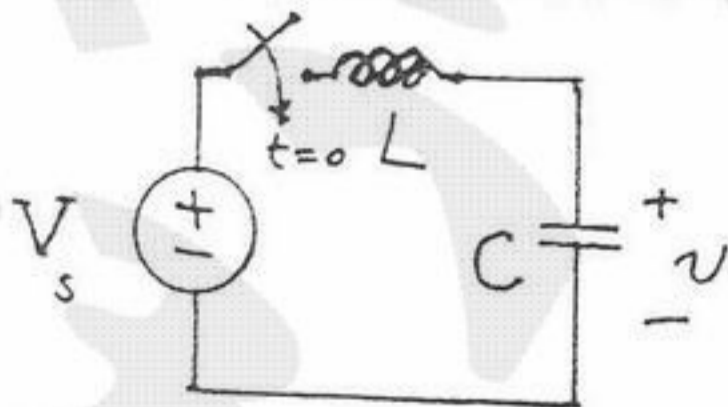

- (۱) $t = \pi\sqrt{LC}$
- (۲) $t = 2\pi\sqrt{LC}$
- (۳) $t = \frac{\sqrt{LC}}{\pi}$
- (۴) امکان ندارد ولتاژ دو سر خازن دو برابر ولتاژ ورودی باشد.

۵۰- اگر در مدار زیر $i_L(0^-) = \frac{4}{15} A$ و $i_L'(0^+) = 2$ باشد $i_C(0^-)$ برابر چند ولت است؟

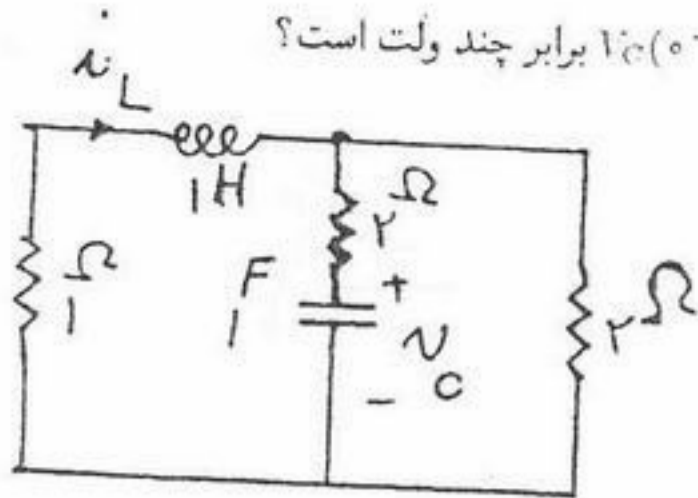

- (۱) -۴
- (۲) $\frac{8}{9}$
- (۳) ۴
- (۴) ۸

۵۱- در مدار شکل مقابل $v_{in}(t) = V_m \cos \omega t$ و مدار در حالت دائمی سینوسی است. در چه فرکانسی رابطه ورودی و خروجی به صورت

$v_o(t) = kv_{in}(t)$ در می آید که k یک مقدار ثابت است و مقدار k کدام است؟

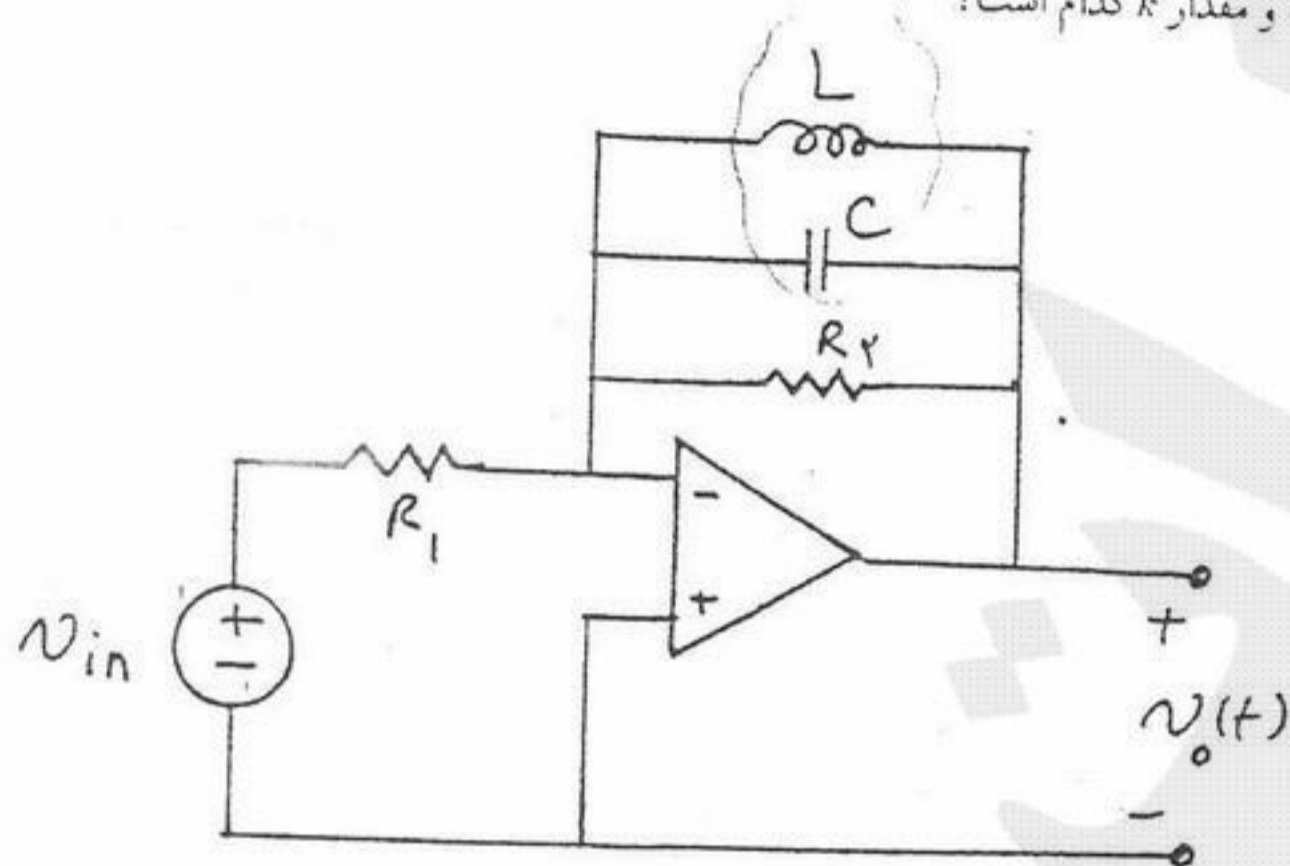

- (۱) $k = -\frac{R_2}{R_1}, \omega = \frac{1}{\sqrt{LC}}$
- (۲) $k = -\frac{R_1}{R_2}, \omega = \frac{1}{\sqrt{LC}}$
- (۳) $k = -\frac{R_2}{R_1}, \omega = \sqrt{\frac{L}{C}}$
- (۴) $k = -\frac{R_1}{R_2}, \omega = \sqrt{\frac{L}{C}}$

۵۲- معادلات حالت یک مدار خطی تغییرناپذیر با زمان به صورت زیر داده شده است، پاسخ ضربه واحد $v_C(t)$ چگونه است؟

$$\frac{d}{dt} \begin{pmatrix} v_C \\ i_L \end{pmatrix} = \begin{pmatrix} 0 & 1 \\ -1 & -1 \end{pmatrix} \begin{pmatrix} v_C \\ i_L \end{pmatrix} + \begin{pmatrix} 1 \\ -1 \end{pmatrix} e(t)$$

که $e(t)$ ورودی مدار و v_C و i_L متغیرهای حالت مدار هستند.

$$v_C(t) = ke^{-\frac{t}{\tau}} \sin\left(\frac{\sqrt{3}}{\tau}t + \theta\right)u(t) \quad (۲)$$

$$v_C(t) = (k_1 + k_2t)e^{-\frac{t}{\tau}}u(t) \quad (۱)$$

$$v_C(t) = kt \sin\left(\frac{\sqrt{3}}{\tau} + \theta\right)u(t) \quad (۴)$$

$$v_C(t) = (k_1e^{-\frac{t}{\tau}} + k_2e^{-\frac{\sqrt{3}}{\tau}t})u(t) \quad (۳)$$

۵۳- کلیدهای S_1 و S_2 در مدار شکل مقابل به طور همزمان بسته می شوند و ولتاژ V دو سر خازن 2 فارادی بعد از بسته شدن کلیدها کدام است؟

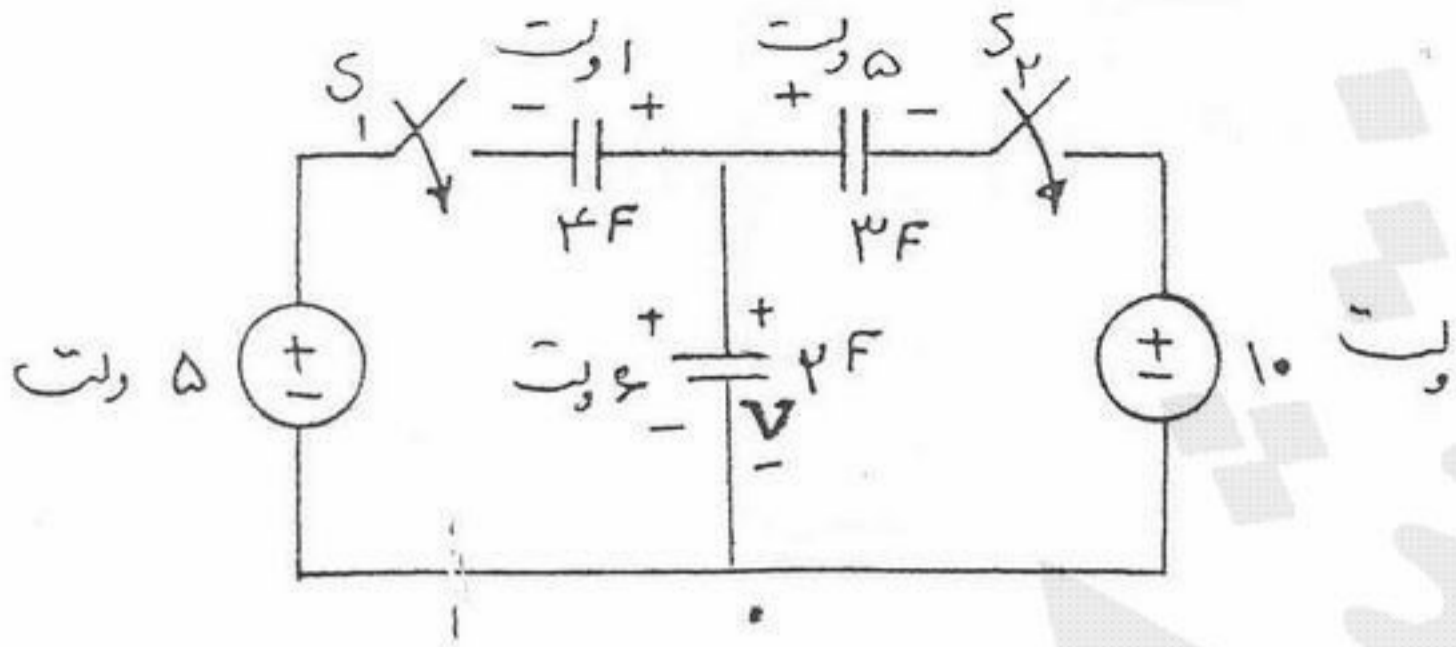

- (۱) ۳
- (۲) ۴
- (۳) ۶
- (۴) ۹

۵۴- در مدار شکل مقابل $e_s = u(-t)$. برای زمان های $t \geq 0$ دیود D چه مدت زمان هادی خواهد ماند؟ (کلید K در $t = 0$ باز می شود).

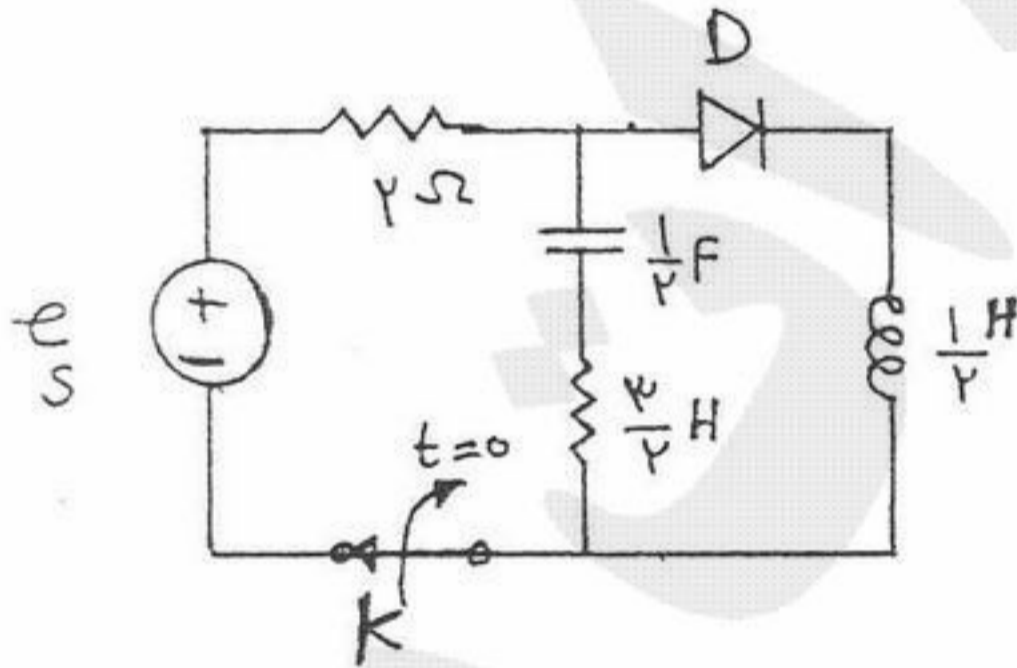

- (۱) π ثانیه
- (۲) $\frac{\pi}{3}$ ثانیه
- (۳) $\frac{\pi}{4}$ ثانیه
- (۴) $\frac{2\pi}{3}$ ثانیه

۵۵- در مدار شکل مقابل مقادیر R_1 و R_2 را چنان انتخاب کنید که رفتار مدار فیلتر پایین گذری باشد که در باند گذر دارای بهره 5 بوده و فرکانس قطع آن 1000 Hz باشد. مقدار C را برابر $\frac{1}{\pi}$ میکروفاراد بگیرید.

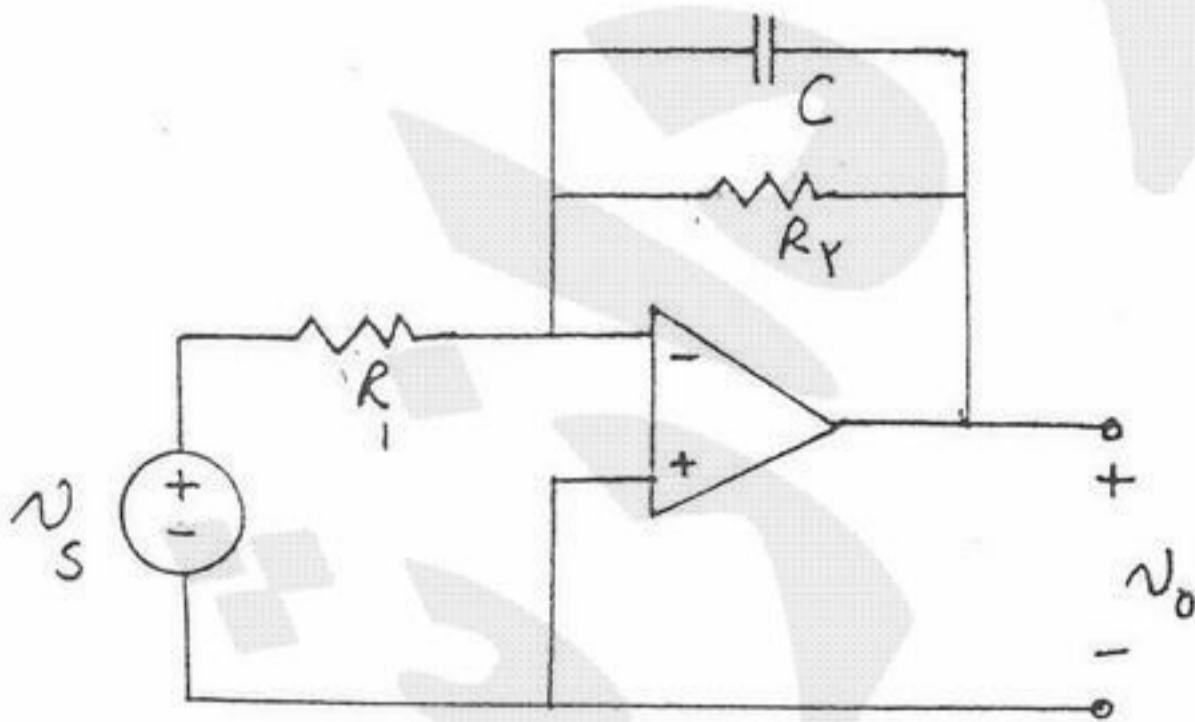

- (۱) $R_2 = 500, R_1 = 100$
- (۲) $R_2 = 100, R_1 = 100$
- (۳) $R_2 = 1000\pi, R_1 = 200\pi$
- (۴) $R_2 = 200\pi, R_1 = 1000\pi$

۵۶ - ماتریس اندوکتانس دو قطبی شکل مقابل کدام است؟

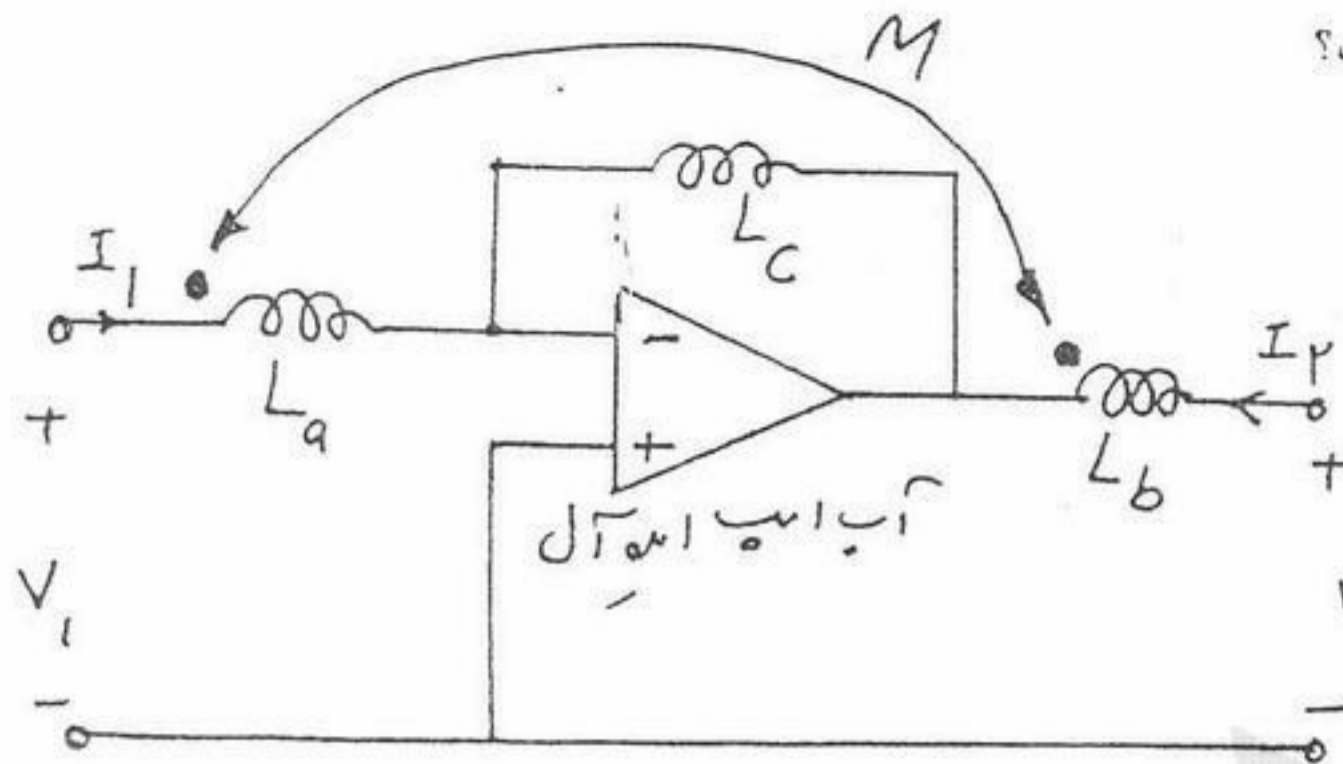

$$\begin{bmatrix} L_a & -M \\ -L_c - M & L_b \end{bmatrix} \quad (1)$$

$$\begin{bmatrix} L_a & -M \\ L_c - M & L_b \end{bmatrix} \quad (2)$$

$$\begin{bmatrix} L_a & M \\ -L_c - M & L_b \end{bmatrix} \quad (3)$$

$$\begin{bmatrix} L_b & -M \\ -L_c - M & L_a \end{bmatrix} \quad (4)$$

۵۷ - مدار شکل مقابل در حالت دائمی سینوسی است. کدام گزینه به عنوان Z_{opt} (از حیث دریافت توان ماکزیمم) می تواند قابل قبول باشد؟

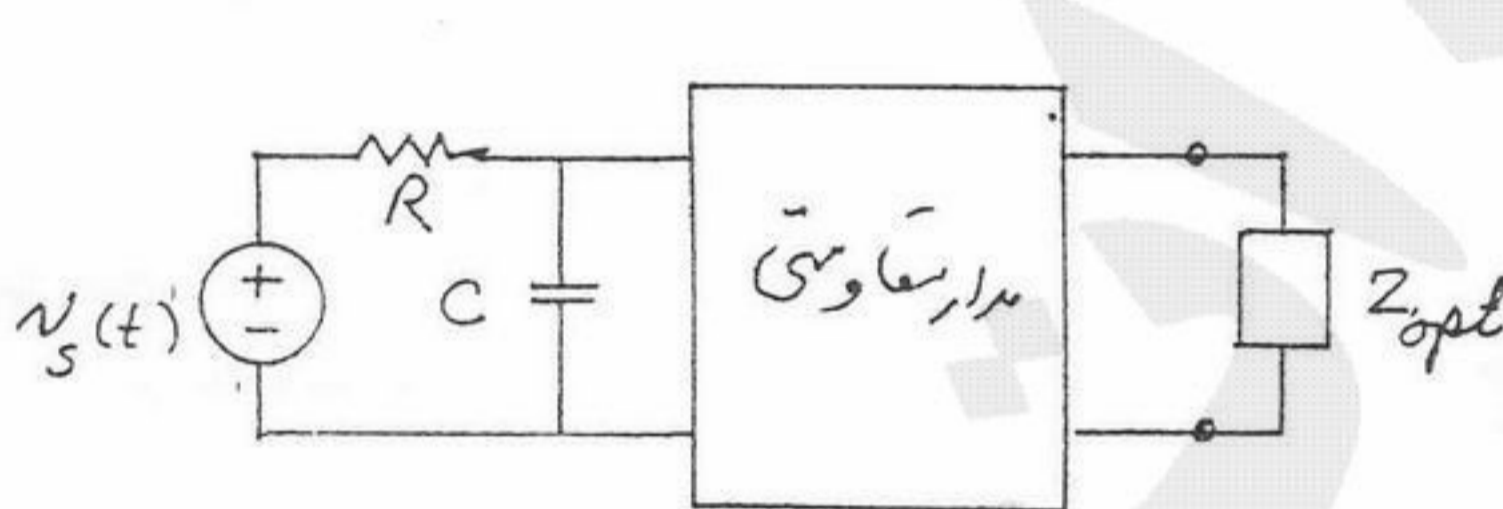

$$j\sqrt{2} \quad (1)$$

$$\sqrt{2} \quad (2)$$

$$1 - j \quad (3)$$

$$1 + j \quad (4)$$

۵۸ - در مدار شکل مقابل سه سلف هر کدام به مقدار یک هانری، سه خازن هر کدام به مقدار دو فاراد و شش مقاومت هر کدام به مقدار سه اهم روی پال های یک مکعب قرار دارند. پاسخ حالت صفر جریان گذرنده از منبع برای ورودی $e_s = u(t)$ کدام است؟ ($C = 2^F, L = 1^H, R = 3^{\Omega}$)

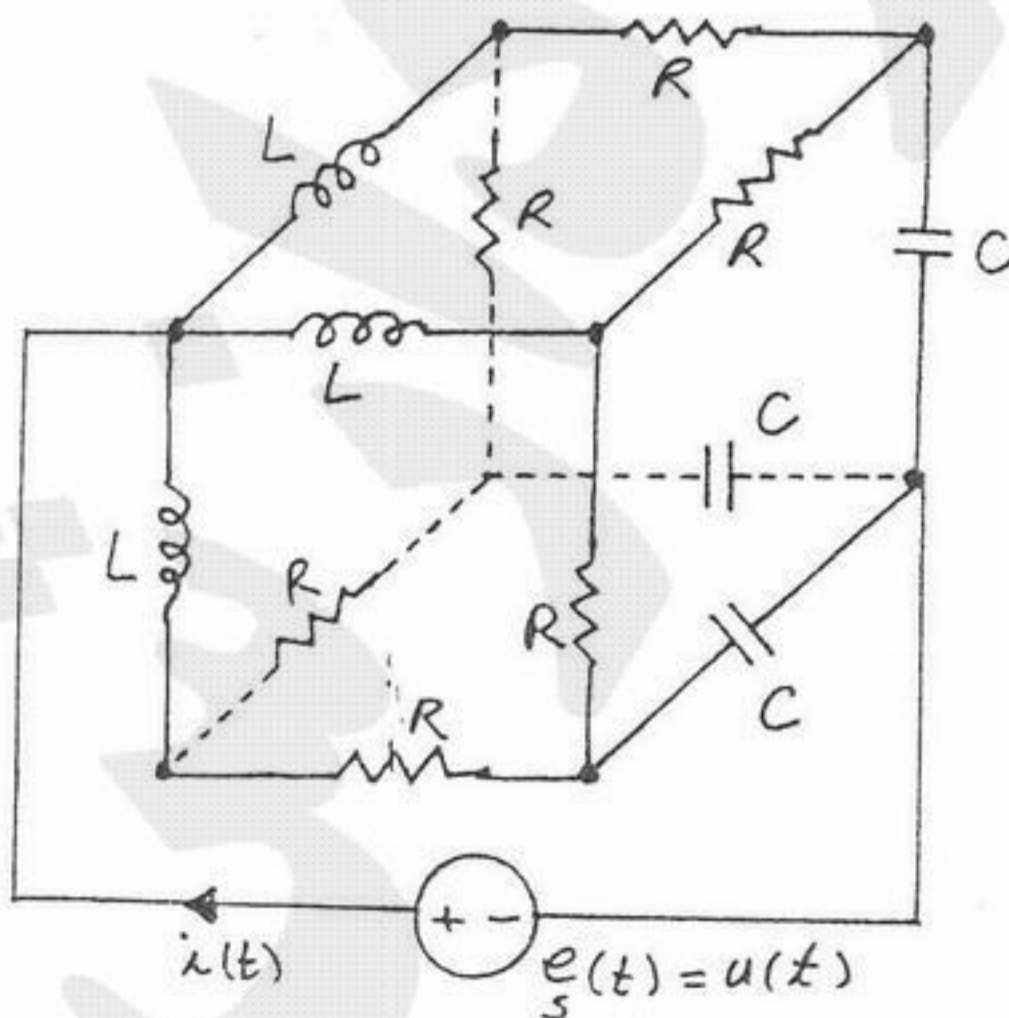

$$i = (2e^{-t} - 2e^{-\frac{1}{2}t})u(t) \quad (1)$$

$$i = (-2e^{-t} + 2e^{-\frac{1}{2}t})u(t) \quad (2)$$

$$i = (-7e^{-t} + 7e^{-\frac{1}{2}t})u(t) \quad (3)$$

$$i = (7e^{-t} - 7e^{-\frac{1}{2}t})u(t) \quad (4)$$

۵۹- معادلات حالت دائمی سینوسی یک مدار به صورت زیر است (ω فرکانس منبع)، (I_1 فازور i_1 و I_2 فازور i_2):

$$\begin{cases} (j\omega - j\frac{2}{\omega})I_1 + (1 - j\frac{1}{\omega})I_2 = 0 \\ (-j\omega + j\frac{2}{\omega})I_1 + (1 + j\omega - j\frac{3}{\omega})I_2 = 1 \end{cases}$$

این مدار:

(۲) با $\omega = \sqrt{2} \neq \omega$ حالت دائمی سینوسی با فرکانس ω دارد.

(۱) با $\omega = \sqrt{2}$ حالت دائمی سینوسی دارد.

(۴) به ازای هر ω حالت دائمی سینوسی دارد.

(۳) با $\omega \neq \sqrt{2}$ حالت دائمی با فرکانس های $\sqrt{2}$ و ω دارد.

۶۰- در مداری از مرتبه ۶ (یعنی باشش فرکانس طبیعی) توابع انتقال $H_1 = \frac{1}{(s+1)(s+2)}$ و $H_2 = \frac{s^2}{(s+1)^2(s+3)}$ و پاسخ ورودی صفر

$v = Ae^{-\frac{1}{3}t}$ معلوم است. کدام دسته از اعداد زیر فرکانس های طبیعی معلوم مدار را نشان می دهند؟

(۲) $-1, -1, -2, -2, -\frac{1}{3}$

(۱) $-1, -1, -1, -2, -2, -\frac{1}{3}$

(۴) موارد ۱ با ۲

(۳) $-1, -2, -2, -\frac{1}{3}$

۶۱- در مدار زیر همه ولتاژها و جریان ها بعد از مدت زمان طولانی 20 ثانیه تقریباً صفر می شوند. اگر مدت زمان طولانی چهار برابر بیشترین ثابت

زمانی ولتاژها و جریان ها باشد آنگاه:

(۱) یک خازن با مقدار حداکثر $\frac{5}{4}F$ است.

(۲) یک مقاومت خطی با مقدار دلخواه R^{Ω} است. ($R \neq -2$)

(۳) یک سلف با مقدار می نیمم $10H$ است.

(۴) موارد ۱ و ۲

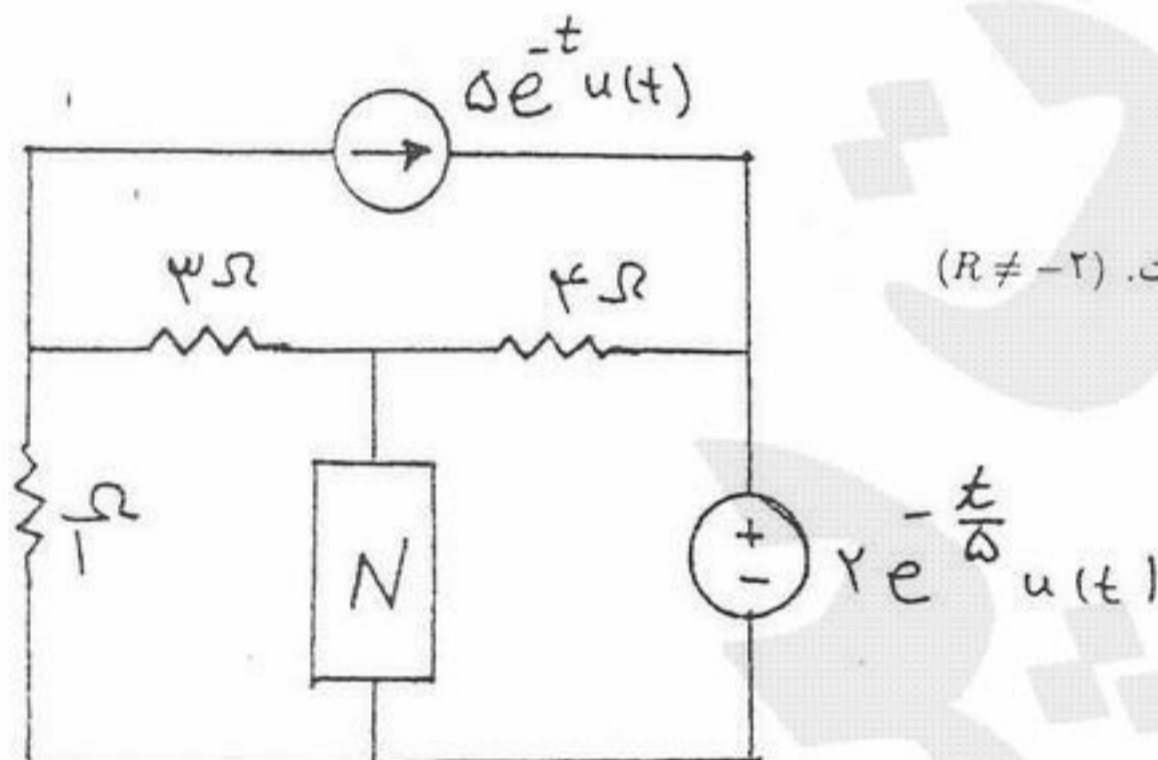

۶۲- در دو قطبی شکل مقابل ماتریس انتقال T کدام است؟ (تعریف زیراتور در شکل زیر داده شده است.)

(تعریف زیراتور)

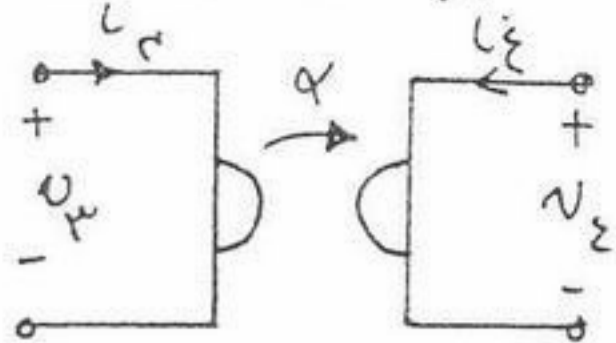

$$\begin{cases} i_p = \alpha v_s \\ i_s = -\alpha v_p \end{cases}$$

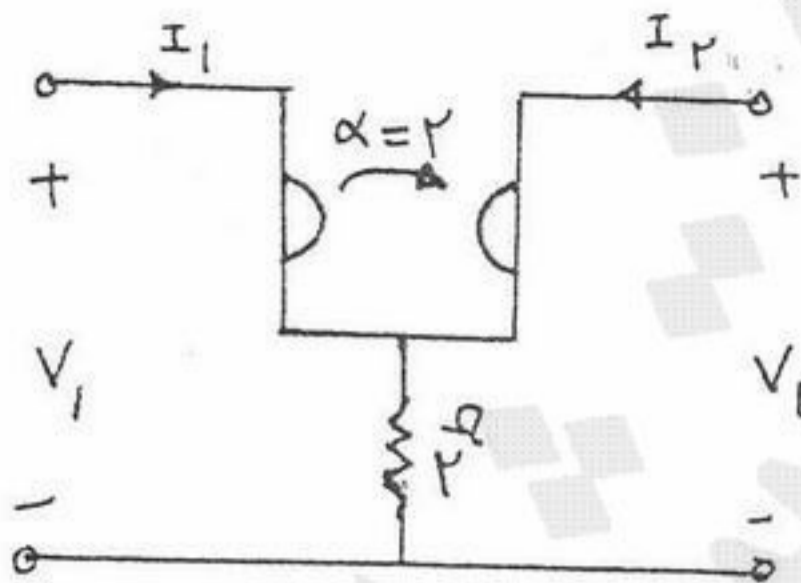

(1) $\begin{pmatrix} 0/8 & 0/1 \\ 0/4 & 0/8 \end{pmatrix}$

(2) $\begin{pmatrix} 0 & 2 \\ 2 & 4 \end{pmatrix}$

(3) $\begin{pmatrix} 2 & 4 \\ 0 & 2 \end{pmatrix}$

(4) $\begin{pmatrix} 2 & 4 \\ 0 & -2 \end{pmatrix}$

۶۳- عکس تبدیل لاپلاس $F(s) = \frac{2e^{-s}}{1+e^{-2s}}$ تابع $f(t)$ است. $f(2/5)$ کدام است؟

(4) ۳

(3) ۲

(2) صفر

(1) -۲

۶۴- تابع شبکه $H(s) = \frac{V_2(s)}{V_1(s)} = \frac{s^2 + as^2 + 0s^2 + bs + c}{2s^2 + 0s^2 + 19s^2 + 8s + 12}$ در مدار شکل زیر داده شده است؟

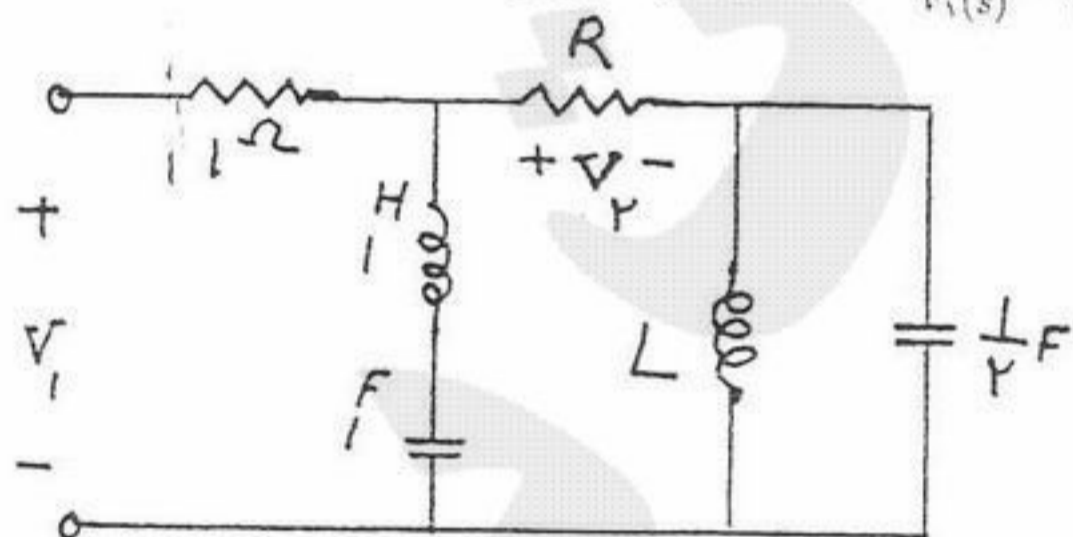

مقادیر مجهول a, b, c کدامند؟

(4) $(a, b, c) = (0, 0, 4)$

(3) $(a, b, c) = (0, 1, 4)$

(2) $(a, b, c) = (1, 0, 4)$

(1) $(a, b, c) = (1, 1, 2)$

۶۵- در مدار شکل مقابل مقاومت غیر خطی با معادله $i_R = v_R^2 + 2v_R$ توصیف می شود. پاسخ ضربه v_R این مدار کدام است؟

(1) $e^{t+ln0} + 1$

(2) $e^{t+ln0} - 1$

(3) $e^{t-ln0} - 1$

(4) $e^{t-ln0} + 1$

